

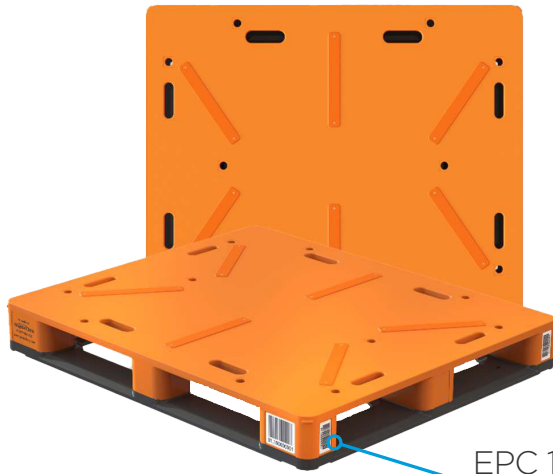

PLASTIC PALLET PROS

PPP Used 48x40 Track Rack Pallet

SKU: PPP 193



EPC 128 Bar Code

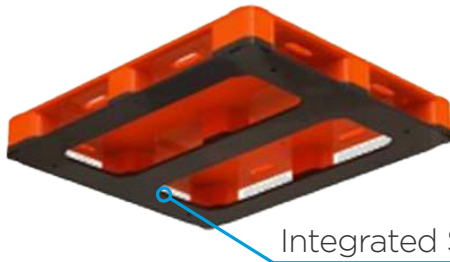

Integrated Steel Reinforcements*

Passive RFID Tag

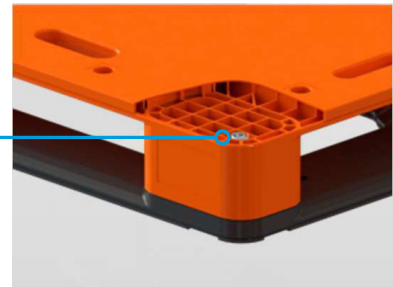

SPECIFICATIONS

DIMENSIONS

Dimensions (L/ W/ H) 1,219 / 1,016 / 140 (mm) 40 / 48 / 5.53 (in)

LOGISTICS

Weight	50 (LB)
Maximum Load Dynamic	5,600 (LB)
Maximum Load Static	14,000 (LB)
Racking Capacity	2,800 (LB)

MATERIAL

Material: HDPE

*Integrated Steel Reinforcements add an extra layer of stability and strength when used in racking systems and when double stacking



PPP Used 48x40 Track Rack Pallet

SKU: PPP 193

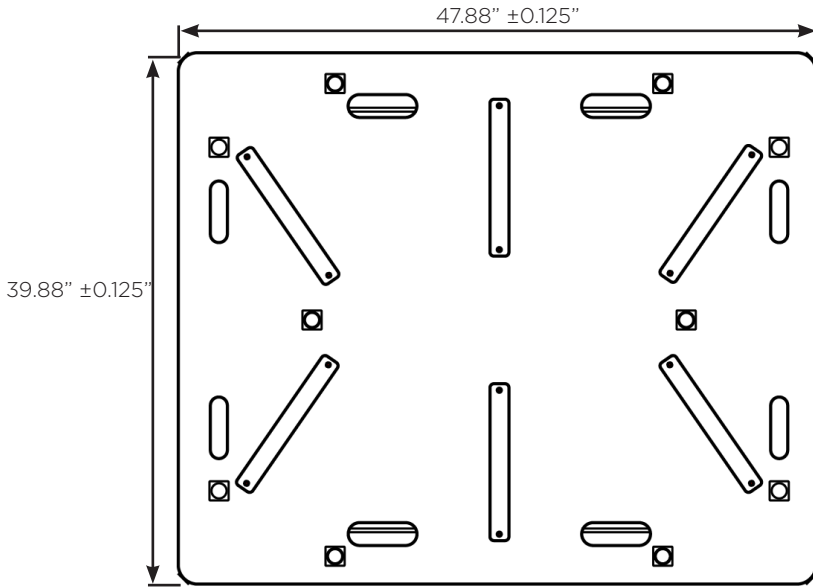

DETAIL C

