

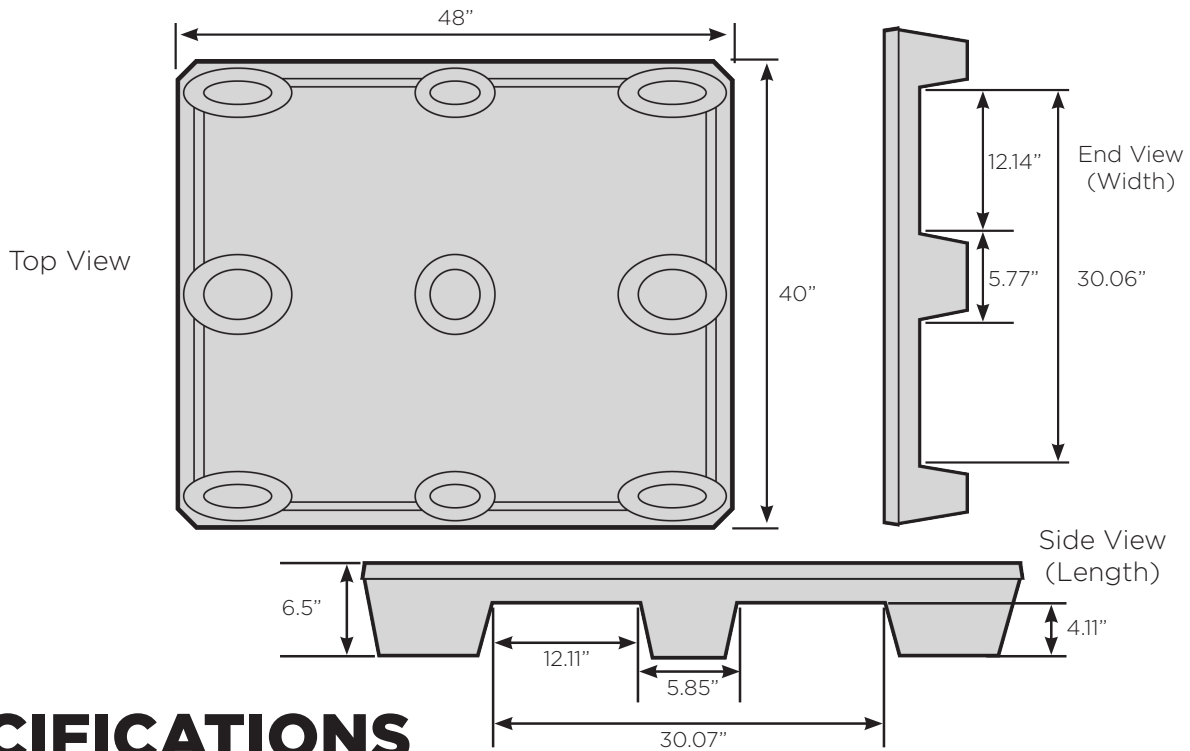

**PLASTIC**  
**PALLET PROS**

# RRM G4.4840

SKU: RRM N2401 48.40



## SPECIFICATIONS

### DIMENSIONS

Dimensions (L/ W/ H)                      1,219 / 1,016 / 168 (mm)                      48 / 40 / 6.63 (in)

### LOGISTICS

Weight	24 (LB)
Maximum Load Dynamic	2,500 (LB)
Maximum Load Static	9,000 (LB)
Pallet Per Stack	40

**53' Truckload - Quantity - 1,200**

### MATERIAL (If Applicable)

Color: Black  
Material: HMWPE



# RRM G4.4840

SKU: RRM N2401 48.40

Perimeter Safety Lip

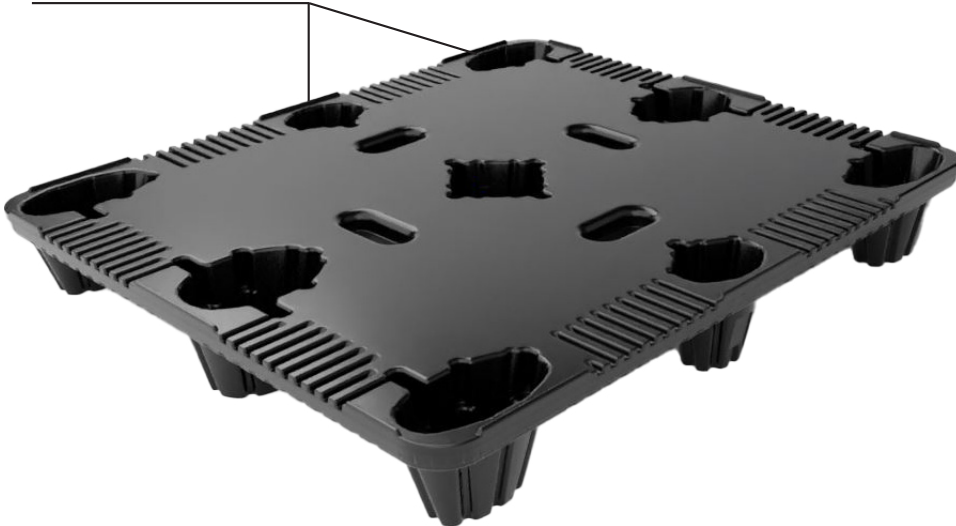

Bottom View

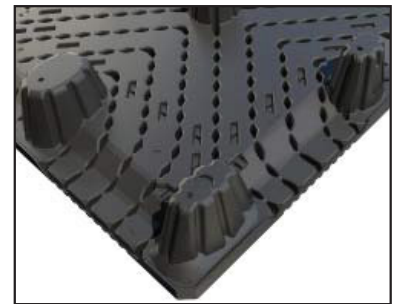

- Twin Sheet thermoformed construction ensures long life and lowest cost per pallet trip
- Drain holes in each pallet foot
- Easy to clean deck surface
- Full Four-Way entry for ease in handling
- Beveled bottom edge allows for easy de-stacking
- Nestable with most other grocery and consumer product industry nestable pallet
- Additional plastic added to the bottom of pallet feet extends pallet life
- 45° corners increase usable deck to reduce case over-hang & damage
- Improved stiffness in both the 40" and 48" directions
- Redesigned edge improves impact resistance and side splitting