



PLASTIC
PALLET PROS

RRM G3.4840

SKU: RRM N2402 48.40



Drain holes on each
of the 9 nesting feet



SPECIFICATIONS

DIMENSIONS

Dimensions (L/ W/ H)

1,219 / 1,016 / 165 (mm)

48 / 40 / 6.5 (in)

LOGISTICS

| | |
|----------------------|------------|
| Weight | 22 (LB) |
| Maximum Load Dynamic | 2,500 (LB) |
| Maximum Load Static | 2,500 (LB) |
| Pallet Per Stack | 40 |

53' Truckload - Quantity - 1,200

MATERIAL (If Applicable)

Color: Black

Material: MWPE



RRM G3.4840

SKU: RRM N2402 48.40

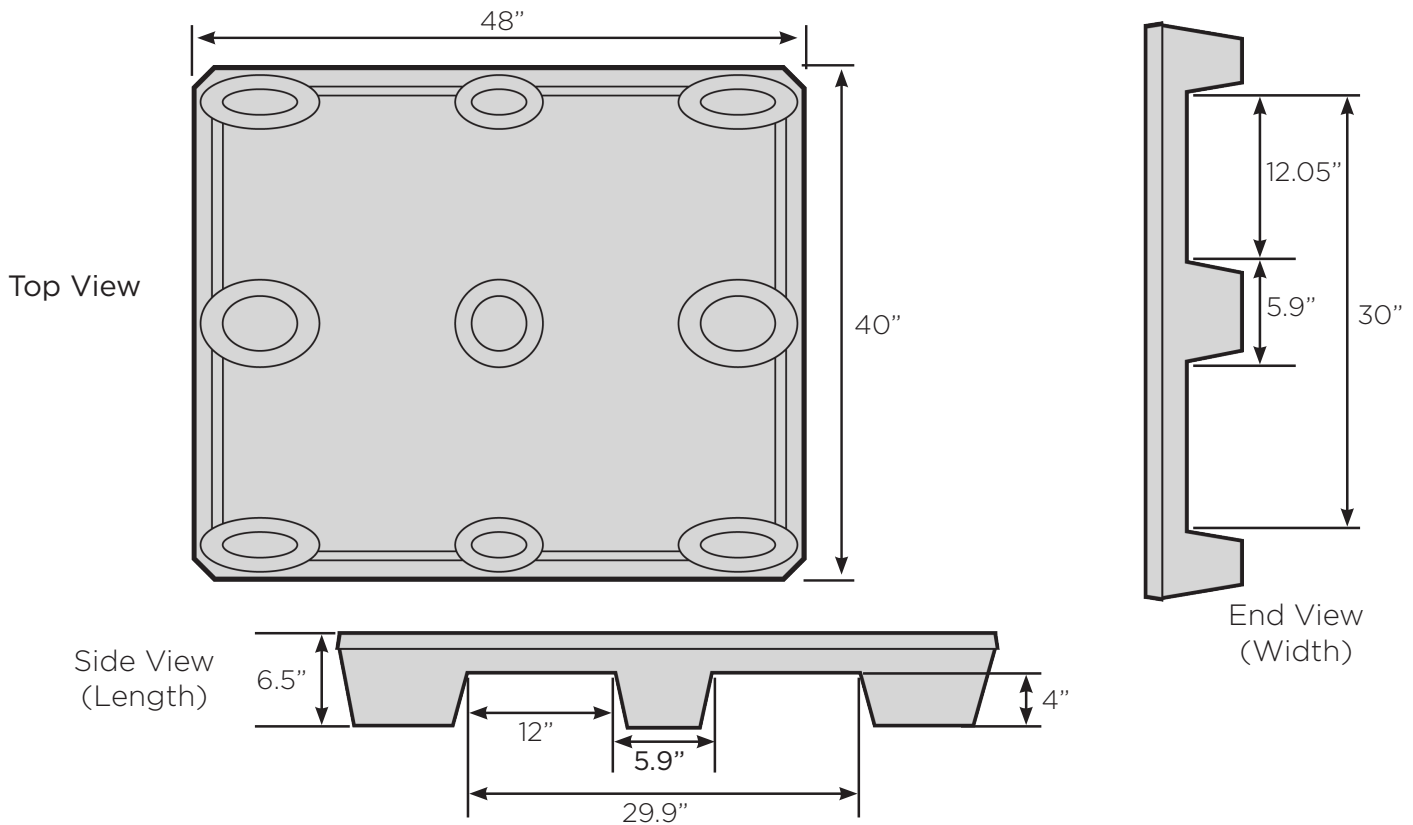

- Drain holes in each pallet foot
- Beveled bottom edge allows for easy de-stacking
- Nestable with other plastic pallets (twin sheet and injection molded pallets)
- Four-way fork entry for Fork Truck and Pallet Jacks
- Lightweight
- Easy to clean deck surface
- 100% recyclable
- Twin-Sheet construction eliminates the need for repair and reduces product damage
- Conveyable and extremely durable